



Trust it

ACCUMULATORI

ACCUMULATORS



Portaci nel futuro, saremo al tuo
fianco nelle tue prossime sfide.

Trust it.

Take us to the future and we will stand
by your side as you face new challenges.

Trust it.

INDEX

ACCUMULATORI

ACCUMULATORS

AZIENDA	COMPANY	p. 2
---------	---------	------

01

ACCUMULATORI A SACCA	BLADDER ACCUMULATORS	p. 5
----------------------	----------------------	------

In accordo EC (2014/68/EU-PED)	Design EC (2014/68/EU-PED)	p. 9
--------------------------------	----------------------------	------

In accordo ASME U-STAMP	Design ASME U-STAMP	p. 10
-------------------------	---------------------	-------

In accordo RINA	Design RINA	p. 11
-----------------	-------------	-------

Saldati in accordo ASME VIII div I U-STAMP	Welded according to ASME VIII div I U-STAMP	p. 12
--	---	-------

02

ACCUMULATORI A MEMBRANA	DIAPHRAGM ACCUMULATORS	p. 15
-------------------------	------------------------	-------

03

ACCUMULATORI A PISTONE	PISTON ACCUMULATORS	p. 21
------------------------	---------------------	-------

04

ACCESSORI E APPLICAZIONI	ACCESSORIES AND APPLICATIONS	p. 27
--------------------------	------------------------------	-------



▶ PROGETTAZIONE PROJECTS

Il moderno e qualificato ufficio tecnico progetta e sviluppa nuovi prodotti ed esegue progetti speciali su richiesta del cliente.

The modern and qualified technical Department is skilled in designing and develop new products and it is ready to support every customer's request with special solutions.



▶ QUALITÀ QUALITY

È un punto di forza di OMT Group e viene costantemente controllata nella moderna e attrezzata sala prove. OMT Group è conforme ai requisiti del Sistema Gestione Qualità ISO 9001:2015.

Is a strong point of OMT Group and it is constantly monitored in the modern and equipped test room. OMT Group complies with the requirements of the standard for the Quality Management System ISO 9001:2015.



▶ INDUSTRIA 4.0 INDUSTRY 4.0

OMT Group ha conseguito l'attestazione di conformità come industria 4.0: la nostra produzione industriale è del tutto automatizzata e interconnessa.

OMT Group obtained the certificate of conformity as Industry 4.0: our industrial production is completely automated and interconnected.



▶ MAGAZZINO WAREHOUSE

La tempestività della consegna è garantita dal magazzino di 1.800 mq e dalla gestione informatizzata.

The timeliness of the delivery is guaranteed by the warehouse of 1,800 square meters and the computerized management.



▶ OMT GROUP WORLDWIDE

La rete commerciale, preparata ed efficiente, offre un servizio ed una consulenza in tutto il mondo e in tempi rapidi.

The commercial network, prepared and efficient, offers a service and advice around the world and timely.



▶ MADE IN ITALY

L'intera gamma prodotti è realizzata internamente.

The whole product range is made in Italy.

55+

55+ ANNI / YEARS

DALL' ESPERIENZA

From expertise

OMT Group è una realtà dinamica e all'avanguardia, **forte di un'esperienza di oltre 55 anni** nel settore dell'oleodinamica.

Nel 2022 OMT Group incorpora OMT e LUEN, ne raccoglie l'esperienza e programma il cambiamento per il futuro.

OMT Group is a dynamic and modern enterprise, **with over 55 years of experience** in hydraulics.

In 2022 OMT Group combines the expertise of OMT and LUEN, using it to plan changes for the future.



ALL' INNOVAZIONE

To innovation

L'**innovazione** presuppone non solo l'aumento di spazi, il potenziamento degli impianti e dei macchinari, ma un **programma** da realizzare con un **gruppo unico, coeso**, in grado di rispondere alle richieste di un mercato in continua evoluzione.

Innovation does not just involve changing premises and upgrading plants and machinery, but also includes carrying out a **programme** as a **single, cohesive group**, able to respond to the demands of a constantly changing market.

GAMMA PRODOTTI

Products range

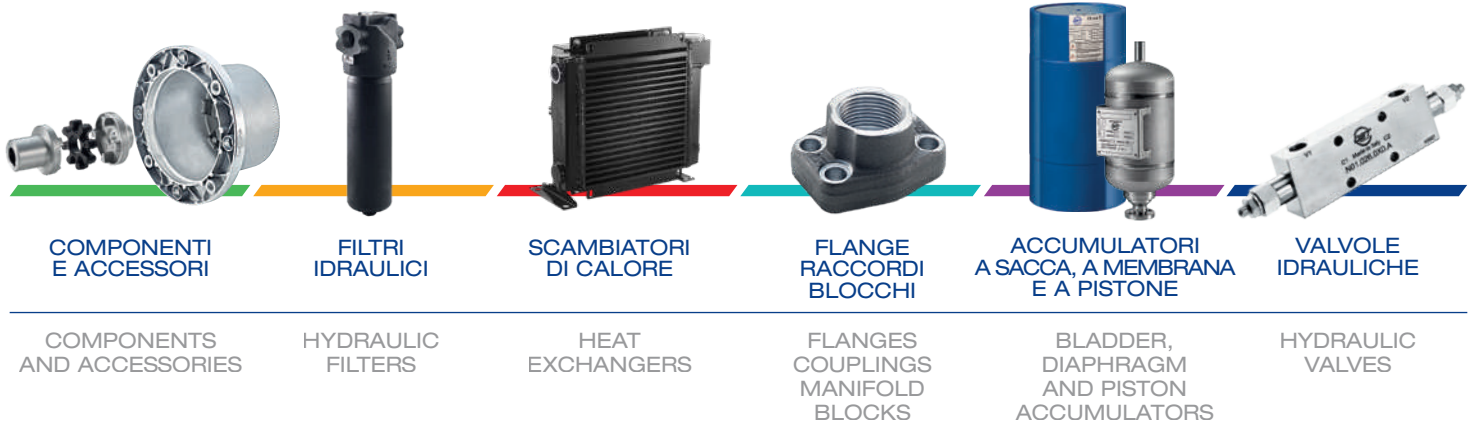

COMPONENTI
E ACCESSORI

COMPONENTS
AND ACCESSORIES

FILTRI
IDRAULICI

HYDRAULIC
FILTERS

SCAMBIATORI
DI CALORE

HEAT
EXCHANGERS

FLANGE
RACCORDI
BLOCCHI

FLANGES
COUPLINGS
MANIFOLD
BLOCKS

ACCUMULATORI
A SACCA, A MEMBRANA
E A PISTONE

BLADDER,
DIAPHRAGM
AND PISTON
ACCUMULATORS

VALVOLE
IDRAULICHE

HYDRAULIC
VALVES

Un accumulatore idropneumatico è un dispositivo utilizzato specificamente per lo stoccaggio di liquidi in pressione. Poiché i liquidi, per tutti gli scopi pratici, sono incompressibili, questo obiettivo viene raggiunto utilizzando la compressibilità dei gas. Un separatore di gomma flessibile, cioè la vescica è inserito nel guscio dell'accumulatore.

A hydro-pneumatic accumulator is a device used specifically for storage of liquid under pressure. As liquids, for all practical purposes, are incompressible, this objective is achieved by utilizing the compressibility of gases.

A flexible rubber separator i.e., bladder is fitted into the accumulator shell.



Trust it

ACCUMULATORI
A SACCA

BLADDER
ACCUMULATORS



ACCUMULATORE IDROPNEUMATICO

Gli accumulatori permettono l'accumulo di liquidi in pressione, essendo questi ultimi praticamente incompressibili.

L'accumulatore trattiene, immagazzina e restituisce fluido in pressione, basandosi sulla differenza di compressione che si crea tra gas e liquido.

PERCHE' UTILIZZARE L'ACCUMULATORE?

L'accumulatore migliora le caratteristiche dell'intero sistema, generando i seguenti vantaggi:

- miglioramento delle funzioni;
- allungamento della vita di esercizio;
- riduzione dei costi di esercizio e manutenzione;
- riduzione delle pulsazioni e dei rumori.

HIDROPNEUMATIC ACCUMULATOR

Accumulators allow fluid accumulation under pressure, the latter being practically incompressible.

The accumulator holds, stores, and returns fluid under pressure, based on the difference of compression that is created between gas and liquid.

WHY USE ACCUMULATOR?

The accumulator improves characteristics of entire system, generating the following advantages:

- improvement of functions;
- lengthening of working life;
- reducing cost of operation and maintenance;
- reduction pulse and noise.

FUNZIONAMENTO ACCUMULATORE A SACCA

V0 = Volume di azoto nell'accumulatore

V1 = Volume gas alla minima pressione idraulica

V2 = Volume gas alla massima pressione idraulica

ΔV = Restituzione / stoccaggio tra P1 e P2

P0 = Precarica iniziale accumulatore

P1 = Pressione gas alla minima pressione idraulica

P2 = Pressione gas alla massima pressione idraulica

BLADDER ACCUMULATOR WORKING

V0 = Capacity in nitrogen of the accumulator

V1 = Gas volume at the minimum hydraulic pressure

V2 = Gas volume at the maximum hydraulic pressure

ΔV = Returned and/or stored volume between P1 and P2

P0 = Initial preload of the accumulator

P1 = Gas pressure at the minimum hydraulic pressure

P2 = Gas pressure at the maximum hydraulic pressure

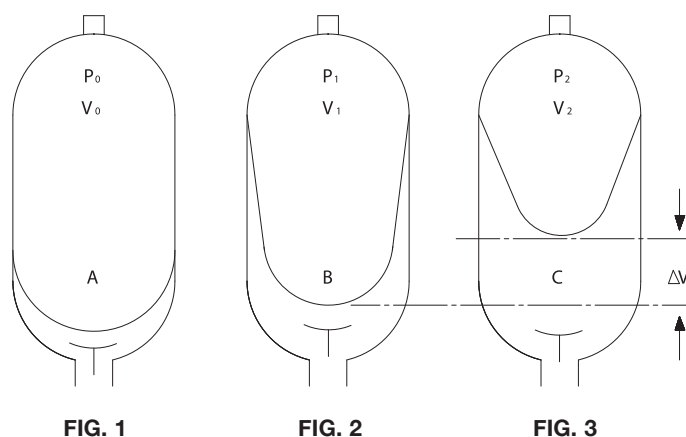

FIG. 1 - grazie alla grande comprimibilità / capacità di compressione dei gas, la sacca montata all'interno del corpo di un accumulatore viene precaricata con azoto.

FIG. 1 - thanks to the large compressibility / compression capacity of gas, bag mounted within body of the accumulator is pre-charged with nitrogen.

FIG. 2 - aggiungendo del liquido in pressione nell'accumulatore, otteniamo una compressione dell'azoto all'interno della sacca.

FIG. 2 - adding liquid under pressure in the accumulator, we obtain a compression of the nitrogen inside the bag.

FIG. 3 - il volume gassoso diminuisce aumentando la pressione e mantenendo in liquido in pressione.

FIG. 3 - the volume of gas decreases by increasing the pressure and keeping the liquid under pressure.

L'accumulatore a sacca riparabile è composto da un corpo forgiato o saldato in acciaio al carbonio o acciaio inox, una sacca sostituibile, una valvola connessione azoto e una valvola connessione olio completa delle guarnizioni di tenuta.

A seconda delle applicazioni, dei fluidi e del paese di destinazione, OMT Group sarà in grado di suggerire la scelta più idonea, selezionando i suddetti componenti.

Repairable bladder accumulator includes a carbon steel/stainless steel, forged/welded body, a repairable bladder, a nitrogen valve connection and an oil valve connection with seals.

Depending on application, fluid and country destination, OMT Group will be able to suggest most appropriate choice concerning these components.

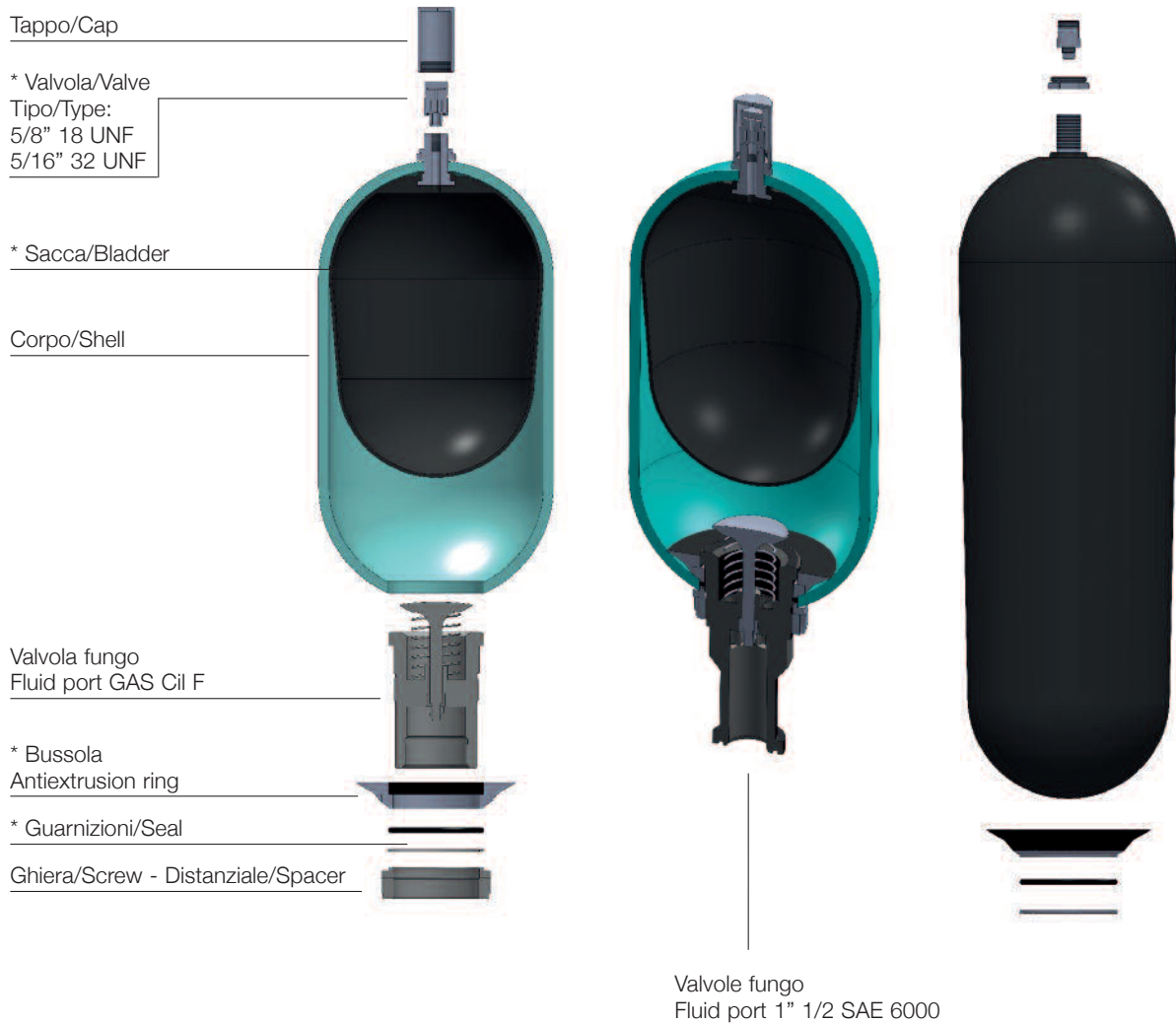

* Ricambi consigliati
 Suggested spare parts

Tutti gli accumulatori verranno consegnati con sabbiatura a mano di fondo RAL 5005

Su richiesta si possono effettuare cicli di verniciatura a specifica e/o per aree off shore

Volumi fino a 500L pressioni fino a 10000psi

Pressione massima di lavoro fino a 470bar @ 120°C MDMT -45°C

Elastomeri compatibili con ogni tipo di fluido ed esigenza (alcuni esempi)

- elastomero standard T (-15/+90)°C
- elastomero basse temperature T (-28/+80)°C
- elastomero bassissime temperature T (-32/+115)°C
- elastomero in Butile T(-15/+120)°C
- elastomero in Viton T (-20/+140)°C

All accumulators will be delivered with sandblasting treatment and primer RAL 5005

On request will be organize special painting cycle and/to off shore area

Volumes up to 500L pressure up to 10000psi

Maximum working pressure 470bar @ 120°C MDMT -45°C

Elastomer compatible with all fluids and applications type (some examples)

- standard elastomer T (-15/+90)°C
- low Temperature elastomer T (-28/+80)°C
- very Low temperature T (-32/+115)°C
- butyl elastomer T(-15/+120)°C
- Viton elastomer T (-20/+140)°C

CAMPI DI UTILIZZO

- riserva di energia;
- funzione di emergenza e sicurezza;
- diminuzione delle vibrazioni, antipulsazioni, anticolpo di ariete, sospensioni idrauliche;
- stabilizzazione del flusso di aspirazione (compensatore di energia);
- regolazione del volume del flusso e perdite dovute ad un cambiamento della temperatura in un circuito idraulico chiuso, mantenendone la pressione;
- trasferimenti di pressione;
- accumulatori transfert (fluido/ fluido).

CHANGES OF USE

- power reserve;
- emergency function and safety;
- reduction of vibrations, Antipulsation, anti-stroke ram, hydraulic suspension;
- stabilization of the flow of intake air (compensator of energy);
- adjusting the volume of flow and losses due to a
- change in temperature in a closed hydraulic circuit, keeping the pressure;
- transfer of pressure;
- accumulators transfer (fluid / fluid).

MONTAGGIO

Si consiglia il montaggio dell'accumulatore in posizione verticale, con lato olio in basso.

E' sconsigliato il montaggio verticale, con il lato olio in alto.

BLADDER ACCUMULATOR WORKING

We recommend vertical position for accumulator fitting, with oil side at the bottom.

It 's not recommended to mount vertically, with oil side up.

Su richiesta costruzione personalizzate

EC (2014/68/EU-PED)
 CU-TR - CoC (ex GOST)
 ARH Algerino
 API 614
 AS1210 Australian Standard
 Canadian Register
 RINA - ABS - LLOYD'S
 NR13
 ASME VIII DIV I U-STAMP

Su richiesta disponibili :

- dischi rottura / valvola lato azoto CE PED
- flange lato impianto a disegno
- spurghi lato impianto aggiuntivi
- connessioni speciali lato fluido BSP/ NPT

On request special construction

EC (2014/68/EU-PED)
 CU-TR - CoC (ex GOST)
 ARH Algerino
 API 614
 AS1210 Australian Standard
 Canadian Register
 RINA - ABS - LLOYD'S
 NR13
 ASME VIII DIV I U-STAMP

On request :

- burst disc CE PED / safety valves CE PED
- special oil flanges connection
- special oil drains
- special oil connection BSP / NPT

ACCUMULATORI A SACCA ACCIAIO AL CARBONIO HIGH BLADDER EUROPEAN CARBON STEEL ACCUMULATORS

01

DESIGN CE (2014/68/EU-PED)
(1-50)L (350/355/380)BAR @ T(-45/+120)°C

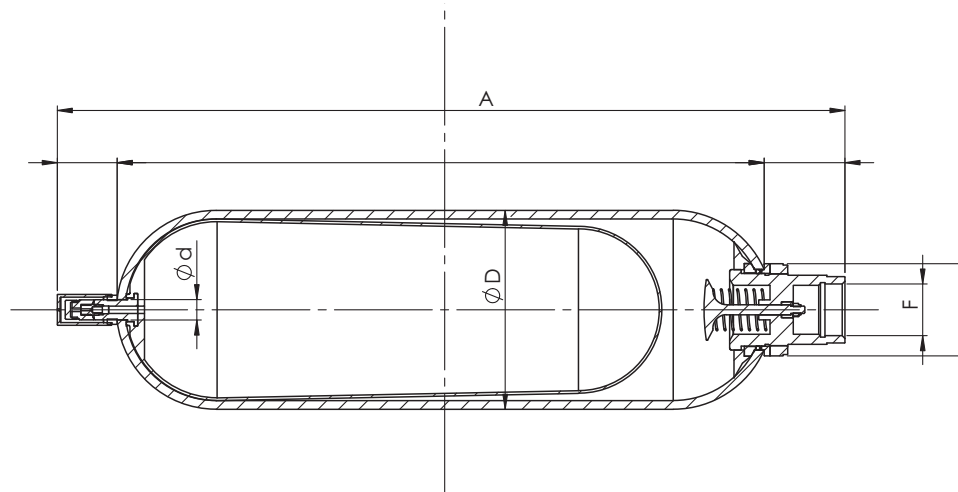

Codice OMT Group Europeo OMT Group European code	Descrizione senza precarica Description without precharge	Volume "L" Volum "L"	MAWP "Bar"	Connessione azoto Nitrogen connection	Connessione olio Oil connection
A-51C-E001NK-DC	ACC. 1 380BAR CE M10X5/8" NBR 3/4"	1	380	5/8" M10x1,5	3/4" gas cil f
A-51C-E02.5NK-CC	ACC. 2.5 350BAR CE M10X5/8" NBR 1 1/4"	2,5	350	5/8" M10x1,5	1"1/4 gas cil f
A-51C-E004NK-CC	ACC. 4 350BAR CE M10X5/8" NBR 1 1/4"	4	350	5/8" M10x1,5	1"1/4 gas cil f
A-51C-E005NK-CC	ACC. 5 350BAR CE M10X5/8" NBR 1 1/4"	5	350	5/8" M10x1,5	1"1/4 gas cil f
A-51C-E006NK-CC	ACC. 6 350BAR CE M10X5/8" NBR 1 1/4"	6	350	5/8" M10x1,5	1"1/4 gas cil f
A-51C-E010NK-AC	ACC. 10 355BAR CE M10X5/8" NBR 2"	10	355	5/8" M10x1,5	2" gas cil f
A-51C-E020NK-AC	ACC. 20 355BAR CE M10X5/8" NBR 2"	20	355	5/8" M10x1,5	2" gas cil f
A-51C-E024.5NK-AC	ACC. 24.5 355BAR CE M10X5/8" NBR 2"	24,5	355	5/8" M10x1,5	2" gas cil f
A-51C-E032NK-AC	ACC. 32 355BAR CE M10X5/8" NBR 2"	32	355	5/8" M10x1,5	2" gas cil f
A-51C-E050NK-AC	ACC. 50 355BAR CE M10X5/8" NBR 2"	50	355	5/8" M10x1,5	2" gas cil f

Codice OMT Group OMT Group code	Kg	A mm	D mm	d mm	N2 valv	Portata fluido Fluid port F	Flusso massimo Flow max l/min
A-51C-E001NK-DC	6	328	115	22	5/8"	3/4" gas cil f	244
A-51C-E02.5NK-CC	11	548	115	22	5/8"	1"1/4 gas cil f	450
A-51C-E004NK-CC	14	420	169	22	5/8"	1"1/4 gas cil f	450
A-51C-E005NK-CC	19	897	115	22	5/8"	1"1/4 gas cil f	450
A-51C-E006NK-CC	20	559	170	22	5/8"	1"1/4 gas cil f	450
A-51C-E010NK-AC	30	568	219	22	5/8"	2" gas cil f	900
A-51C-E020NK-AC	50	888	219	22	5/8"	2" gas cil f	900
A-51C-E024.5NK-AC	53	1028	219	22	5/8"	2" gas cil f	900
A-51C-E032NK-AC	80	1380	219	22	5/8"	2" gas cil f	900
A-51C-E050NK-AC	100	1885	219	22	5/8"	2" gas cil f	900

ACCUMULATORI A SACCA ACCIAIO AL CARBONIO

HIGH BLADDER EUROPEAN CARBON STEEL ACCUMULATORS

DESIGN ASME U-STAMP
(10-50)L (3000/10000)PSI @ T(-40/+93)°C

Codice OMT Group Europeo OMT Group European code	Descrizione senza precarica Description without precharge	Volume "L" Volum "L"	MAWP "Psi/Bar"	Connessione azoto Nitrogen connection	Connessione olio Oil connection
A-51CEU010NK-AC	ACC. 10 3000Psi U STAMP M10X5/8" NBR 2"	10	3000/320	5/8" M10x1,5	2" gas cil f
A-51CEU020NK-AC	ACC. 20 3000Psi U STAMP M10X5/8" NBR 2"	20	3000/320	5/8" M10x1,5	2" gas cil f
A-51CEU024.5NK-AC	ACC. 24.5 3000Psi U STAMP M10X5/8" NBR 2"	24,5	3000/320	5/8" M10x1,5	2" gas cil f
A-51CEU032NK-AC	ACC. 32 3000Psi U STAMP M10X5/8" NBR 2"	32	3000/320	5/8" M10x1,5	2" gas cil f
A-51CEU050NK-AC	ACC. 50 3000Psi U STAMP M10X5/8" NBR 2"	50	3000/320	5/8" M10x1,5	2" gas cil f

Codice OMT Group Europeo OMT Group European code	Descrizione senza precarica Description without precharge	Volume "L" Volum "L"	MAWP "Psi"	Connessione azoto Nitrogen connection	Connessione olio Oil connection
A-51C4U010NK-AC	ACC. 10 4000Psi U STAMP M10X5/8" NBR 2"	10	4000	5/8" M10x1,5	2" gas cil f
A-51C4U020NK-AC	ACC. 20 4000Psi U STAMP M10X5/8" NBR 2"	20	4000	5/8" M10x1,5	2" gas cil f
A-51C4U024.5NK-AC	ACC. 24.5 4000Psi U STAMP M10X5/8" NBR 2"	24,5	4000	5/8" M10x1,5	2" gas cil f
A-51C4U032NK-AC	ACC. 32 4000Psi U STAMP M10X5/8" NBR 2"	32	4000	5/8" M10x1,5	2" gas cil f
A-51C4U050NK-AC	ACC. 50 4000Psi U STAMP M10X5/8" NBR 2"	50	4000	5/8" M10x1,5	2" gas cil f

Codice OMT Group Europeo OMT Group code	Descrizione senza precarica Description without precharge	Volume "L" Volum "L"	MAWP "Psi"	Connessione azoto Nitrogen connection	Connessione olio Oil connection
A-51C6U010NK-AC	ACC. 10 6666Psi U STAMP M10X5/8" NBR 2"	10	6666	5/8" M10x1,5	2" gas cil f
A-51C6U020NK-AC	ACC. 20 6666Psi U STAMP M10X5/8" NBR 2"	20	6666	5/8" M10x1,5	2" gas cil f
A-51C6U024.5NK-AC	ACC. 24.5 6666Psi U STAMP M10X5/8" NBR 2"	24,5	6666	5/8" M10x1,5	2" gas cil f
A-51C6U032NK-AC	ACC. 32 6666Psi U STAMP M10X5/8" NBR 2"	32	6666	5/8" M10x1,5	2" gas cil f
A-51C6U050NK-AC	ACC. 50 6666Psi U STAMP M10X5/8" NBR 2"	50	6666	5/8" M10x1,5	2" gas cil f

Codice OMT Group Europeo OMT Group European code	Descrizione senza precarica Description without precharge	Volume "L" Volum "L"	MAWP "Psi"	Connessione azoto Nitrogen connection	Connessione olio Oil connection
A-51C1U010NK-AC	ACC. 10 10000Psi U STAMP M10X5/8" NBR 2"	10	10000	5/8" M10x1,5	2" gas cil f
A-51C1U020NK-AC	ACC. 20 10000Psi U STAMP M10X5/8" NBR 2"	20	10000	5/8" M10x1,5	2" gas cil f
A-51C1U024.5NK-AC	ACC. 24.5 10000Psi U STAMP M10X5/8" NBR 2"	24,5	10000	5/8" M10x1,5	2" gas cil f
A-51C1U032NK-AC	ACC. 32 10000Psi U STAMP M10X5/8" NBR 2"	32	10000	5/8" M10x1,5	2" gas cil f
A-51C1U050NK-AC	ACC. 50 10000Psi U STAMP M10X5/8" NBR 2"	50	10000	5/8" M10x1,5	2" gas cil f

Codice OMT Group Europeo OMT Group code	Kg EU/4	Kg 6	Kg 1	D EU/4 mm	D 6 mm	D 1 mm	d mm	N2 valv	Portata fluidio Fluid port F	Flusso massimo Flow max l/min
A-51C(EU4/6/1)010NK-AC	30	36	95	219	245	267	22	5/8"	2" gas cil f	900
A-51C(EU4/6/1)020NK-AC	50	54	134	219	245	267	22	5/8"	2" gas cil f	900
A-51C(EU4/6/1)024.5NK-AC	53	75	170	219	245	267	22	5/8"	2" gas cil f	900
A-51C(EU4/6/1)032NK-AC	80	100	227	219	245	267	22	5/8"	2" gas cil f	900
A-51C(EU4/6/1)050NK-AC	100	138	318	219	245	267	22	5/8"	2" gas cil f	900

ACCUMULATORI A SACCA ACCIAIO AL CARBONIO HIGH BLADDER EUROPEAN CARBON STEEL ACCUMULATORS

01

DESIGN RINA
(1-50)L (340)BAR @ T(-45/+120)°C

Codice OMT Group Europeo OMT Group European code	Descrizione senza precarica Description without precharge	Volume "L" Volum "L"	MAWP "Psi/Bar"	Connessione azoto Nitrogen connection	Connessione olio Oil connection
A-51C-R001NK-DC	ACC. 1 340BAR CE M10X5/8" NBR 3/4"	1	340	5/8" M10x1,5	3/4" gas cil f
A-51C-R02.5NK-CC	ACC. 2.5 340BAR CE M10X5/8" NBR 1 1/4"	2,5	340	5/8" M10x1,5	1"1/4 gas cil f
A-51C-R004NK-CC	ACC. 4 340BAR CE M10X5/8" NBR 1 1/4"	4	340	5/8" M10x1,5	1"1/4 gas cil f
A-51C-R005NK-CC	ACC. 5 340BAR CE M10X5/8" NBR 1 1/4"	5	340	5/8" M10x1,5	1"1/4 gas cil f
A-51C-R006NK-CC	ACC. 6 340BAR CE M10X5/8" NBR 1 1/4"	6	340	5/8" M10x1,5	1"1/4 gas cil f
A-51C-R010NK-AC	ACC. 10 340BAR CE M10X5/8" NBR 2"	10	340	5/8" M10x1,5	2" gas cil f
A-51C-R020NK-AC	ACC. 20 340BAR CE M10X5/8" NBR 2"	20	340	5/8" M10x1,5	2" gas cil f
A-51C-R024.5NK-AC	ACC. 24.5 340BAR CE M10X5/8" NBR 2"	24,5	340	5/8" M10x1,5	2" gas cil f
A-51C-R032NK-AC	ACC. 32 340BAR CE M10X5/8" NBR 2"	32	340	5/8" M10x1,5	2" gas cil f
A-51C-R050NK-AC	ACC. 50 340BAR CE M10X5/8" NBR 2"	50	340	5/8" M10x1,5	2" gas cil f

Codice OMT Group OMT Group code	Kg	A mm	D mm	d mm	N2 valv	Portata fluido Fluid port F	Flusso massimo Flow max l/min
A-51C-R001NK-DC	6	328	115	22	5/8"	3/4" gas cil f	244
A-51C-R02.5NK-CC	11	548	115	22	5/8"	1"1/4 gas cil f	450
A-51C-R004NK-CC	14	420	169	22	5/8"	1"1/4 gas cil f	450
A-51C-R005NK-CC	19	897	115	22	5/8"	1"1/4 gas cil f	450
A-51C-R006NK-CC	20	559	170	22	5/8"	1"1/4 gas cil f	450
A-51C-R010NK-AC	30	568	219	22	5/8"	2" gas cil f	900
A-51C-R020NK-AC	50	888	219	22	5/8"	2" gas cil f	900
A-51C-R024.5NK-AC	53	1028	219	22	5/8"	2" gas cil f	900
A-51C-R032NK-AC	80	1380	219	22	5/8"	2" gas cil f	900
A-51C-R050NK-AC	100	1885	219	22	5/8"	2" gas cil f	900

Legenda – Composizione codice

How to order

A	-	51C	-	E	050	NK	-	AC	x	xx	xx	xx	xx	xx	xx
---	---	-----	---	---	-----	----	---	----	---	----	----	----	----	----	----

A: Versione a sacca alta pressione / Bladder version high pressure

51C: Acciaio al carbonio / Carbon Steel

E: CE (2014/68/EU-PED)

EU CE (2014/68/EU-PED) + U Stamp 3000Psi

U: U Stamp

4U: U Stamp 4000Psi

6U: U Stamp 6666Psi

1U: U Stamp 10000Psi

L: Lloyd's

EL: CE (2014/68/EU-PED) + Lloyd's

R: Rina

ER: CE (2014/68/EU-PED) + Rina

Z: Speciali

001-050: Volume in L / Volum L

Tipo di elastomero con gijera in acciaio: Sacca - O ring / Bladder - O Ring

N: Perbunan NBR – standard

B: Butile

V: Viton

L: bassa temperatura -28°C / low temperature

I: bassissima temperatura -32°C / very low temperature

Tipo valvola azoto / nitrogen gas valve

K: 5/8" 18 UNF – M10x1,5 in AISI 304

J: 5/8" 18 UNF – 1/2" 20 UNF in AISI 304

Y: Minimex P1620 - M10x1,5

V: a brugola / screw M28x1,5

W: 5/16" – 32 Schreader

Tipo valvola olio standard in acciaio / steel standard oil port valve

AC: 2" gas cil F (10-50)L

BC: 3/4" gas cil F (10-50)L

CC: 1"1/4 gas cil F (2,5-4-5-6)L

DC: 3/4" gas cil F (1)L

S6: 1"1/2 SAE 6000 (10-50 L)

Tipo valvola olio in acciaio inox 316L / stainless steel AISI 316L oil port valve

AX: 2" gas cil F (10-50)L

BX: 3/4" gas cil F (10-50)L

CX: 1"1/4 gas cil F (2,5-4-5-6)L

DX: 3/4" gas cil F (1)L

X6: 1"1/2 SAE 6000 (10-50 L)

ACCUMULATORI A SACCA IN AISI 316/L BLADDER STAINLESS STEEL ACCUMULATORS

SALDATI IN ACCORDO ASME VIII DIV I U-STAMP
WELDED ACCORDING TO ASME VIII DIV I U-STAMP
(10-50)L 60BAR @ T(-40/+150)°C

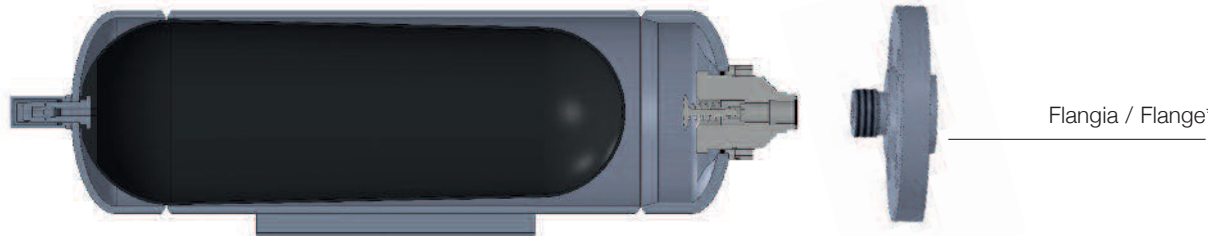

Legenda – Composizione codice

M	B	U	R	S	10	-	57	-	NK	-	xx	xx	xx	xx
---	---	---	---	---	----	---	----	---	----	---	----	----	----	----

How to order

L : bassa pressione / low pressure
M : media pressione / medium pressure
H : alta pressione / high pressure

B : accumulatore a sacca / bladder accumulator

E: EC (2014/68/EU-PED)

U: U Stamp

EU: EC (2014/68/EU-PED) + U STAMP

L: Lloyd's

EL: EC (2014/68/EU-PED) + Lloyd's

R: Rina

ER: EC (2014/68/EU-PED) + Rina

Z: Special

R: riparabile / reparable

S: acciaio inox 316/L / stainless steel AISI 316/L

C: acciaio al carbonio / carbon steel

01-575: Volume in L / Volum L (oltre 50L su richiesta / from 50L to 575L on request)

Tipo di elastomero con ghiera acciaio : Sacca - O ring /
Bladder - O Ring

N: Perbunan NBR – standard

B: Butile

V: Viton

L: bassa temperatura -28°C /
low temperature

I: bassissima temperatura -32°C /
very low temperature

Tipo valvola azoto / nitrogen valve

K: 5/8" 18 UNF – M10x1,5 in AISI 304

J: 5/8" 18 UNF – 1/2" 20 UNF 1A in AISI 304

X: 1/4" BSP – M10x1,5 in AISI 304

Y: Minimex M10x1,5 – M28x1,5

W: 5/16" – 32 Schreder

Tipo valvola olio in acciaio inox 316/L / stainless steel AISI
316/L oil port valve

AX: 2" gas cil F (10-50)L

BX: 3/4" gas cil F (10-50)L

CX: 1"1/4 gas cil F (2,5-4-5-6)L

DX: 3/4" gas cil F (1)L

X6: 1"1/2 SAE 6000 (10-50L)

* Su richiesta flange lato impianto a disegno
On request special oil flange connection

Un accumulatore idropneumatico è un dispositivo utilizzato specificamente per lo stoccaggio di liquidi in pressione. Poiché i liquidi, per tutti gli scopi pratici, sono incompressibili, questo obiettivo viene raggiunto utilizzando la compressibilità dei gas. Un separatore di gomma flessibile, cioè un diaframma, è inserito nel guscio dell'accumulatore.

A hydro-pneumatic accumulator is a device used specifically for storage of liquid under pressure. As liquids, for all practical purposes, are incompressible, this objective is achieved by utilizing the compressibility of gases.

A flexible rubber separator i.e., diaphragm is fitted into the accumulator shell.



Trust it

ACCUMULATORI
A MEMBRANA

DIAPHRAGM
ACCUMULATORS



Caratteristiche degli Accumulatori a Membrana

Unique Diaphragm Accumulator Features

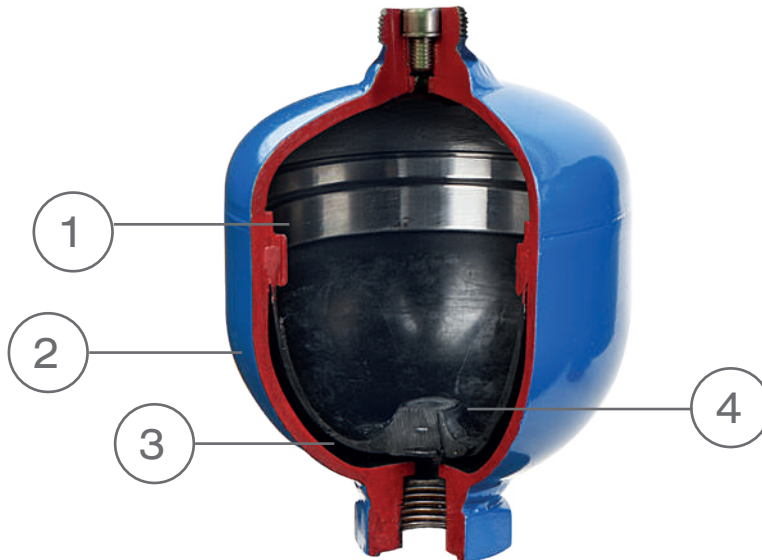

1 Anello metallico di tenuta membrana

- Chiusura di sicurezza della membrana
- Blocco controllo deformazione
- Doppio anello di tenuta

2 Utilizzazione forma del corpo

- Peso ridotto
- Forma compatta
- Ampia gamma di pressioni

3 Ottimizzazione forma membrana e selezione dei materiali

- Miglioramento proprietà di rotazione
- Ampia gamma di temperature
- Bassa permeabilità

4 Alta durata del piatto metallico

- Non vulcanizzato alla membrana
- Permette movimenti veloci della membrana
- Scarico totale del fluido attraverso connessione diretta

1 Metal diaphragm clamping ring

- Secure reproducible clamping force of the diaphragm
- Controlled deformation for locking
- Stable metal ring vs. plastic ring

2 Optimized shape of the shell

- Weight reduction
- Strength integrity
- Wide range of pressure fluctuations

3 Optimized diaphragm shape and material selection

- Improved rolling properties
- Wide temperature range
- Low permeation

4 High durability poppet valve

- Not vulcanized to the diaphragm
- Allows fast motions of diaphragm
- Total discharging of fluid through incorporated discharging channels

Accumulatori Idraulici - Hydraulic Accumulators

Accumulatori di energia/Smorzatori di pulsazioni

Accumulatori idraulici elettrosaldati

- Ampia gamma di prodotti con ottime prestazioni
- Volumi da 0.07 a 3,5 litri
- Pressure di utilizzo fino a 350 bar (alta resistenza allo scoppio)
- Poca e semplice manutenzione
- Lunga durata

Riserva di energia

- Gestione e controllo dell'energia derivante dalle applicazioni idrauliche

Costruzioni per applicazioni speciali

- Disponibilità di varie tipologie di membrana idonee a differenti fluidi ed applicazioni
- Possibilità di controllo della precarica
- Bassa permeabilità

Smorzatori di pulsazioni

- Riduzione di vibrazioni e rumorosità a seguito di picchi di pressione
- Efficienza e lunga durata

Energy Accumulators/Pulsation Dampers

Electron-beam welded Hydraulic Accumulators

- Large volume and performance range
- 0.07 to 3,5 liters
- Pressure range up to 350 bar (high bursting strength)
- Low.maintenance design
- Long service life

Energy accumulation

- Controlled energy delivery for hydraulic applications

Application-specific design

- The most varied diaphragm and housing materials available
- Refillable
- Low permeation

Pulsation damping

- Vibration and noise reduction with pressure surges
- Efficiency and extension of service life

Accumulatori a Membrana

Diaphragm Accumulator

DATI TECNICI - TECHNICAL DATA

Tipo Type	Codice Article (*)	Volume nominale Nominal volume Litri / Litres	Pressione di lavoro permissibile Permissible operating pressure bar	C	E	F	D	H1	Peso Weight Kg.	Rapporto pressione massima Max pressure ratio (**)
MBSP 0,07-250	007.1315.013.6X1	0.07	250	32	G 1/2"	-	66	110.5	0.76	8:1
MBSP 0,16-250	016.1315.024.6X1	0.16	250	32	G 1/2"	-	76	123.5	0.95	8:1
MBSP 0,32-210	032.1315.044.6X1	0.32	210	32	G 1/2"	-	95	139	1.42	8:1
MBSP 0,5-210	050.1315.013.6X1	0.5	210	41	G 1/2"	-	103	152.5	2.00	8:1
MBSP 0,5-210	050.1315.023.6X1	0.5	210	41	G 1/2"	M33x1.5	103	165.5	2.00	8:1
MBSP 0,6-330	060.1315.013.7X1	0.6	330	41	G 1/2"	-	111	170.5	3.00	4:1
MBSP 0,75-210	075.1315.043.6X1	0.75	210	41	G 1/2"	-	122	176	2.52	8:1
MBSP 0,75-210	075.1315.053.6X1	0.75	210	41	G 1/2"	M33x1.5	122	189	2.52	8:1
MBSP 0,75-350	075.1315.012.7X1	0.75	350	41	G 1/2"	-	126	180.5	3.92	8:1
MBSP 0,75-350	075.1315.022.7X1	0.75	350	41	G 1/2"	M33x1.5	126	193.5	3.92	8:1
MBSP 1,0-250	100.1315.083.6X1	1.0	210	41	G 1/2"	-	136	179	4.20	8:1
MBSP 1,0-350	100.1315.043.7X1	1.0	350	41	G 1/2"	-	140	183	5.00	4:1
MBSP 1,0-350	100.1315.053.7X1	1.0	350	41	G 1/2"	M33x1.5	140	196	5.00	4:1
MBSP 1,4-160	140.1315.043.5X1	1.4	140	41	G 1/2"	M33x1.5	146	208	3.94	8:1
MBSP 1,4-210	140.1315.153.6X1	1.4	210	41	G 1/2"	M33x1.5	152	220	5.20	8:1
MBSP 1,4-250	140.1315.112.6X1	1.4	250	41	G 1/2"	-	158	213.1	6.34	8:1
MBSP 1,4-350	140.1315.012.7X1	1.4	350	41	G 1/2"	-	158	213.1	7.00	8:1
MBSP 1,4-350	140.1315.022.7X1	1.4	350	41	G 1/2"	M33x1.5	158	226.1	7.00	8:1
MBSP 2,0-250	200.1315.142.6X1	2.0	250	41	G 3/4"	-	172	242	8.72	6:1
MBSP 2,0-350	200.1315.042.7X1	2.0	350	41	G 3/4"	-	172	242	9.50	6:1
MBSP 2,8-250	280.1315.032.6X1	2.8	250	41	G 3/4"	-	172	268	10.86	4:1
MBSP 3,5-250	350.1315.072.6X1	3.5	250	41	G 3/4"	-	172	321	11.44	4:1

(*)

X equivale alla identificazione del materiale della membrana interna:

- materiale standard NBR (-20/+80)°C = 1
- materiale IIR = 2
- materiale FKM (-10/+150)°C = 3
- materiale ECO (-30/+110)°C = 4
- altri materiali su richiesta

(**)

rapporto di compressione ammissibile per diaframma/membrana
P2 (pressione di lavoro) / PO (pressione di riempimento gas)

(*)

X equates to identification figure at current diaphragm material:

- standard material NBR (-20/+80)°C = 1
- material IIR = 2
- material FKM (-10/+150)°C = 3
- material ECO (-30/+110)°C = 4
- other materials on requiry

(**)

permissible pressure ratio for diaphragm

P2 (pressione di lavoro) / PO (pressione di riempimento gas)

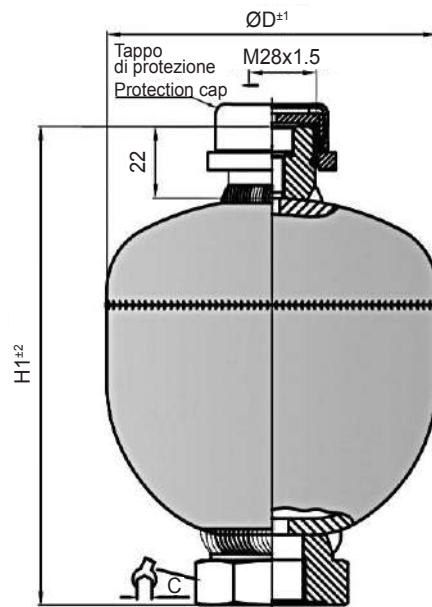

Connessione lato gas
Gas side connection

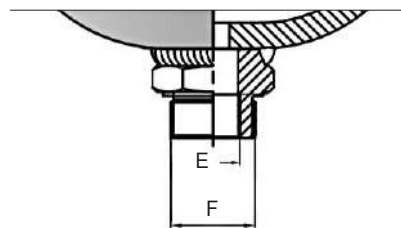
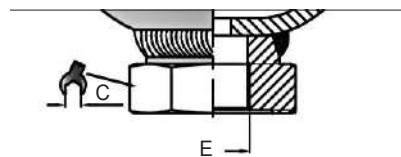
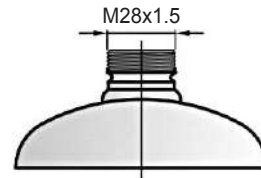

Un accumulatore idropneumatico a pistone è un dispositivo utilizzato specificamente per lo stoccaggio di liquidi in pressione. Poiché i liquidi, per tutti gli scopi pratici, sono incompressibili, questo obiettivo viene raggiunto utilizzando la compressibilità dei gas.

Un pistone flottante è inserito nel tubo dell'accumulatore.

A hydro-pneumatic piston accumulator is a device used specifically for storage of liquid under pressure. As liquids, for all practical purposes, are incompressible, this objective is achieved by utilizing the compressibility of gases.

A floating piston is fitted into the accumulator tube.



Trust it

ACCUMULATORI
A PISTONE

PISTON
ACCUMULATOR



ACCUMULATORI A PISTONE

- Versione Standard (Acciaio)
- In accordo alla CE (2014/68/EU-PED)
Fluid Group 2
- Min. / Max Temperatura
accumulatore ammissibile: -20 / +80 °C
- Codice Kit Guardinizione: KIT-GPACC180NBR

PISTON ACCUMULATOR

- Standard version (Carbon steel)
- According to CE (2014/68/EU-PED)
Fluid Group 2
- Min. / Max. Admissible
accumulator temperature: -20 / +80 °C
- Seal kit Code: KIT-GPACC180NBR

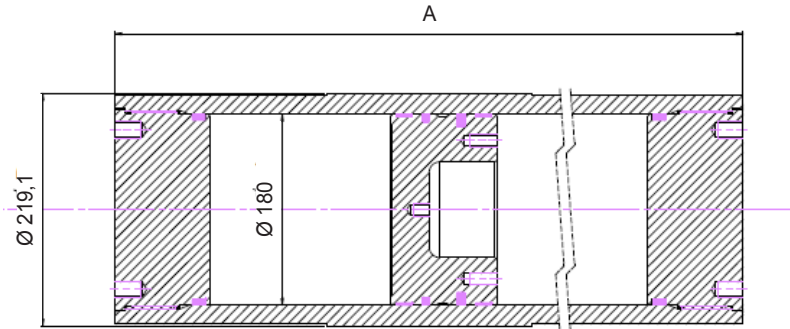

Tipo Type	Volume effettivo Gas Effective Gas volume Litri / Litres	A - Altezza Max A - Max Height mm	Peso Weight Kg.
PEA-C-180-N-008-25C	8	594	96
PEA-C-180-N-010-25C	10	673	103
PEA-C-180-N-015-25C	15	869	121
PEA-C-180-N-020-25C	20	1066	139
PEA-C-180-N-025-25C	25	1262	157
PEA-C-180-N-039-25C	30	1459	175
PEA-C-180-N-035-25C	35	1655	193
PEA-C-180-N-040-25C	40	1852	211
PEA-C-180-N-045-25C	45	2048	230
PEA-C-180-N-050-25C	50	2245	248
PEA-C-180-N-055-25C	55	2441	266
PEA-C-180-N-060-25C	60	2638	284
PEA-C-180-N-065-25C	65	2834	302
PEA-C180-N-070-25C	70	3031	320
PEA-C180-N-075-25C	75	3227	338

ACCUMULATORI A PISTONE

- Versione Standard (Acciaio)
- In accordo alla CE (2014/68/EU-PED)
Fluid Group 2
- Min. / Max Temperatura
accumulatore ammissibile: -20 / +80 °C
- Codice Kit Guardinazione: KIT-GPACC250NBR

PISTON ACCUMULATOR

- Standard version (Carbon steel)
- According to CE (2014/68/EU-PED)
Fluid Group 2
- Min. / Max. Admissible
accumulator temperature: -20 / +80 °C
- Seal kit Code: KIT-GPACC250NBR

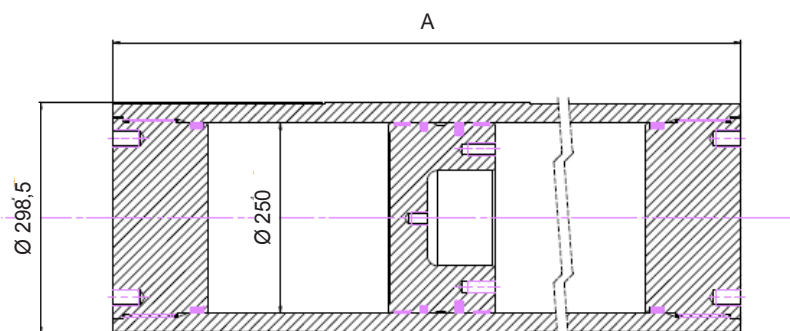

Tipo Type	Volume effettivo Gas Effective Gas volume Litri / Litres	A - Altezza Max A - Max Height mm	Peso Weight Kg.
PEA-C-250-N-020-250	20	757	213
PEA-C-250-N-025-250	25	859	229
PEA-C-250-N-030-250	30	961	245
PEA-C-250-N-035-250	35	1063	261
PEA-C-250-N-040-250	40	1165	277
PEA-C-250-N-045-250	45	1267	293
PEA-C-250-N-050-250	50	1369	309
PEA-C-250-N-055-250	55	1470	325
PEA-C-250-N-060-250	60	1572	341
PEA-C-250-N-065-250	65	1674	357
PEA-C-250-N-070-250	70	1776	373
PEA-C-250-N-075-250	75	1878	389
PEA-C-250-N-080-250	80	1980	405
PEA-C-250-N-085-250	85	2082	421
PEA-C-250-N-090-250	90	2183	437
PEA-C-250-N-095-250	95	2285	453
PEA-C-250-N-100-250	100	2387	469
PEA-C-250-N-105-250	105	2489	485
PEA-C-250-N-110-250	110	2591	501
PEA-C-250-N-115-250	115	2693	517
PEA-C-250-N-120-250	120	2795	533
PEA-C-250-N-125-250	125	2896	549
PEA-C-250-N-130-250	130	2998	565
PEA-C-250-N-135-250	135	3100	581
PEA-C-250-N-140-250	140	3202	597
PEA-C-250-N-145-250	145	3304	613
PEA-C-250-N-150-250	150	3406	629
PEA-C-250-N-155-250	155	3508	645
PEA-C-250-N-160-250	160	3609	661
PEA-C-250-N-165-250	165	3711	677
PEA-C-250-N-170-250	170	3813	693
PEA-C-250-N-175-250	175	3915	709
PEA-C-250-N-180-250	180	4017	725
PEA-C-250-N-185-250	185	4119	741
PEA-C-250-N-190-250	190	4221	757
PEA-C-250-N-195-250	195	4323	773
PEA-C-250-N-200-250	200	4424	789

ACCUMULATORI A PISTONE

- Versione Standard (Acciaio)
- In accordo alla CE (2014/68/EU-PED)
Fluid Group 2
- Min. / Max Temperatura
accumulatore ammissibile: -20 / +80 °C
- Codice Kit Guarnizione: KIT-GPACC350NBR

PISTON ACCUMULATOR

- Standard version (Carbon steel)
- According to CE (2014/68/EU-PED)
Fluid Group 2
- Min. / Max. Admissible
accumulator temperature: -20 / +80 °C
- Seal kit Code: KIT-GPACC350NBR

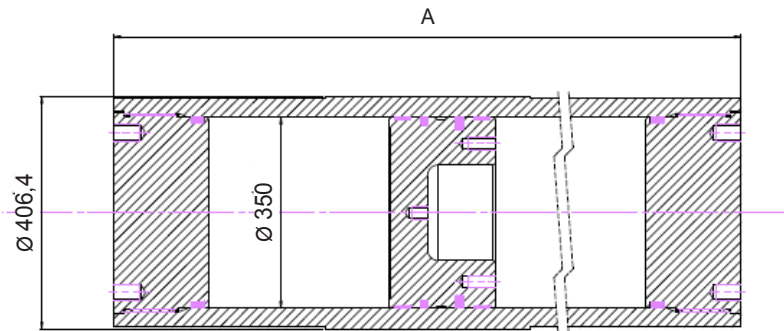

Tipo Type	Volume effettivo Gas Effective Gas volume	A - Altezza Max A - Max Height	Peso Weight
	Litri / Litres	mm	Kg.
PEA-C-350-N-030-250	30	742	415
PEA-C-350-N-040-250	40	846	441
PEA-C-350-N-050-250	50	950	467
PEA-C-350-N-060-250	60	1054	494
PEA-C-350-N-070-250	70	1158	520
PEA-C-350-N-080-250	80	1262	546
PEA-C-350-N-090-250	90	1365	572
PEA-C-350-N-100-250	100	1469	598
PEA-C-350-N-110-250	110	1573	624
PEA-C-350-N-120-250	120	1677	650
PEA-C-350-N-130-250	130	1781	676
PEA-C-350-N-140-250	140	1885	702
PEA-C-350-N-150-250	150	1989	728
PEA-C-350-N-160-250	160	2093	754
PEA-C-350-N-170-250	170	2197	780
PEA-C-350-N-180-250	180	2301	807
PEA-C-350-N-190-250	190	2405	833
PEA-C-350-N-200-250	200	2509	859
PEA-C-350-N-210-250	210	2613	885
PEA-C-350-N-220-250	220	2717	911
PEA-C-350-N-230-250	230	2821	937
PEA-C-350-N-240-250	240	2925	963
PEA-C-350-N-250-250	250	3028	989
PEA-C-350-N-260-250	260	3132	1015
PEA-C-350-N-270-250	270	3236	1041
PEA-C-350-N-280-250	280	3340	1067
PEA-C-350-N-290-250	290	3444	1093
PEA-C-350-N-300-250	300	3548	1120
PEA-C-350-N-310-250	310	3652	1146
PEA-C-350-N-320-250	320	3756	1172
PEA-C-350-N-330-250	330	3860	1198
PEA-C-350-N-340-250	340	3964	1224
PEA-C-350-N-350-250	350	4068	1250
PEA-C-350-N-360-250	360	4172	1276
PEA-C-350-N-370-250	370	4276	1302
PEA-C-350-N-380-250	380	4380	1328
PEA-C-350-N-390-250	390	4484	1354
PEA-C-350-N-400-250	400	4588	1381

Accessori e applicazioni disponibili:

- sacca con imballo speciale
- mensola
- collare per accumulatore a sacca
- collare per accumulatore a membrana
- Gruppo di controllo pressione azoto
- kit di ricarica azoto
- blocco di sicurezza accumulatori
- valvola di sicurezza accumulatori
- applicazioni di accumulatori a membrana
- costruzioni speciali

Available accessories and applications:

- bladder with special package
- bracket
- clamp for bladder accumulators
- clamp for diaphragm accumulators
- nitrogen control pressure kit
- universal Nitrogen charging kit
- safety block Accumulators
- safety valve Accumulators
- applications of diaphragm accumulators
- special projects



Trust it

ACCESSORI
E APPLICAZIONI

ACCESSORIES
AND APPLICATIONS



SACCA CON IMBALLO SPECIALE BLADDER WITH SPECIAL PACKAGE

SOLO PER ACCUMULATORI A SACCA
ONLY FOR BLADDER ACCUMULATORS

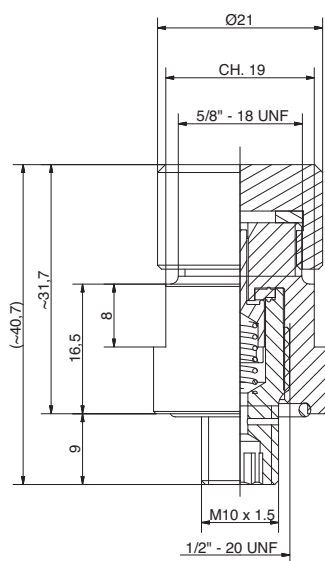
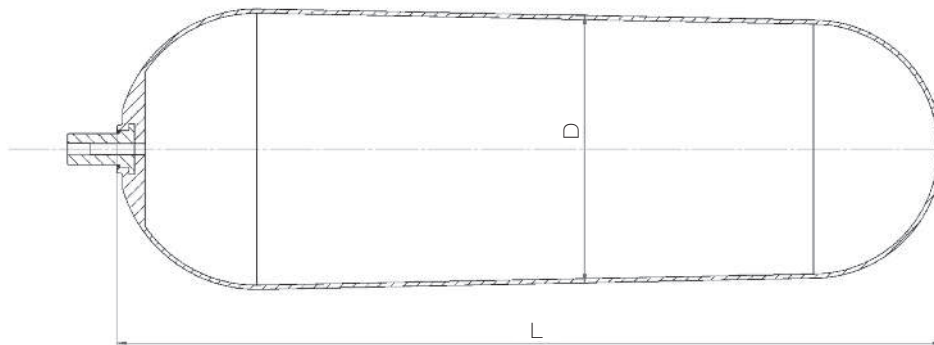

Tipo di valvola
Valve type

006.226.000.T
"K"

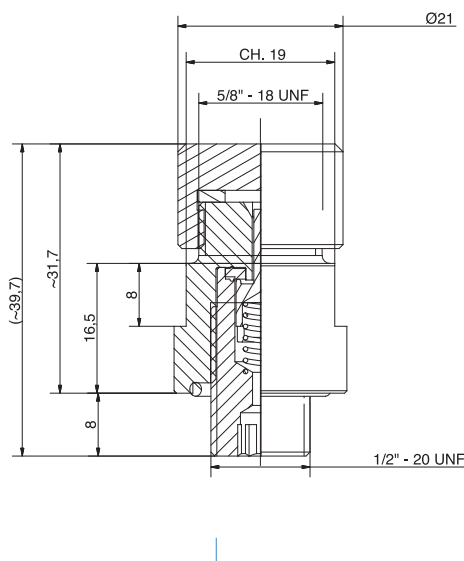

006.227.000.T
"J"

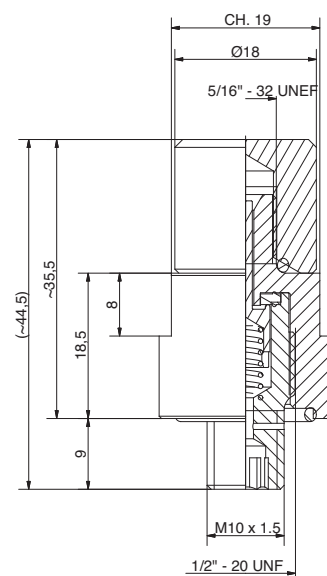

006.228.000.T
"W"

Codice OMT Group accumulatore a sacca NBR + valvola 5/8" Code OMT Group NBR bladder + 5/8" valve 006.226.000.T (K)	Descrizione Description	L (mm)	D	N2 Connettore valvola Valve connection	Diametro esterno sacca Bladder external diameter	Standard (NBR)
SACCA-IMB-1-22NK	sacca 1L Diam 22 M10x1,5	149+/-5	100	5/8" 18UNF	7/8" 14UNF 1A	-15/+100
SACCA-IMB-2,5-22NK	sacca 2,5L Diam 22 M10x1,5	331+/-5	100	5/8" 18UNF	7/8" 14UNF 1A	-15/+100
SACCA-IMB-4-22NK	sacca 4L Diam 22 M10x1,5	208+/-10	150	5/8" 18UNF	7/8" 14UNF 1A	-15/+100
SACCA-IMB-5-22NK	sacca 5L Diam 22 M10x1,5	682+/-10	100	5/8" 18UNF	7/8" 14UNF 1A	-15/+100
SACCA-IMB-6-22NK	sacca 6L Diam 22 M10x1,5	426+/-10	150	5/8" 18UNF	7/8" 14UNF 1A	-15/+100
SACCA-IMB-10-22NK	sacca 10L Diam 22 M10x1,5	286+/-10	200	5/8" 18UNF	7/8" 14UNF 1A	-15/+100
SACCA-IMB-10-50NK	sacca 10L Diam 50 M10x1,5	286+/-10	200	5/8" 18UNF	7/8" 14UNF 1A	-15/+100
SACCA-IMB-20-22NK	sacca 20L Diam 22 M10x1,5	590+/-10	200	5/8" 18UNF	7/8" 14UNF 1A	-15/+100
SACCA-IMB-20-50NK	sacca 20L Diam 50 M10x1,5	590+/-10	200	5/8" 18UNF	7/8" 14UNF 1A	-15/+100
SACCA-IMB-24,5-22NK	sacca 24,5L Diam 22 M10x1,5	732+/-10	200	5/8" 18UNF	7/8" 14UNF 1A	-15/+100
SACCA-IMB-24,5-50NK	sacca 24,5L Diam 50 M10x1,5	732+/-10	200	5/8" 18UNF	7/8" 14UNF 1A	-15/+100
SACCA-IMB-32-22NK	sacca 32L Diam 22 M10x1,5	1114+/-15	200	5/8" 18UNF	7/8" 14UNF 1A	-15/+100
SACCA-IMB-32-50NK	sacca 32L Diam 50 M10x1,5	1114+/-15	200	5/8" 18UNF	7/8" 14UNF 1A	-15/+100
SACCA-IMB-50-22NK	sacca 50L Diam 22 M10x1,5	1611+/-15	200	5/8" 18UNF	7/8" 14UNF 1A	-15/+100
SACCA-IMB-50-50NK	sacca 50L Diam 50 M10x1,5	1611+/-15	200	5/8" 18UNF	7/8" 14UNF 1A	-15/+100

**SOLO PER ACCUMULATORI A SACCA
ONLY FOR BLADDER ACCUMULATORS**

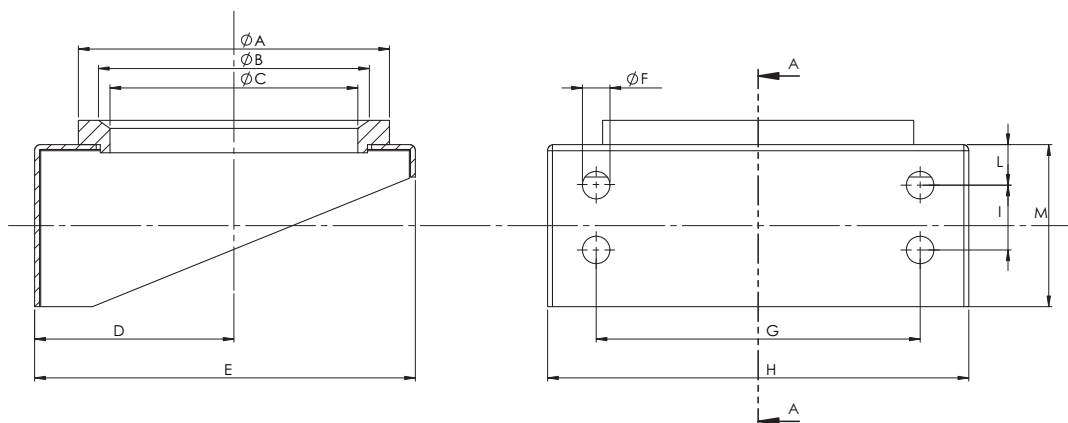

Codice OMT Group OMT Group code	Descrizione Description	A	B	C	D	E	F	G	H	I	L	M
MENSOLA-C-89	MENSOLA C DIAM.89	125	101	89	73	140	13	75	130	-	25	60
MENSOLA-C-108	MENSOLA C DIAM.108	150	120	108	92	175	17	160	210	-	25	80
MENSOLA-C-159	MENSOLA C DIAM.159	200	170	159	123	235	17	200	260	40	25	100

**COLLARE
CLAMP**

**PER ACCUMULATORI A SACCA
FOR BLADDER ACCUMULATORS**

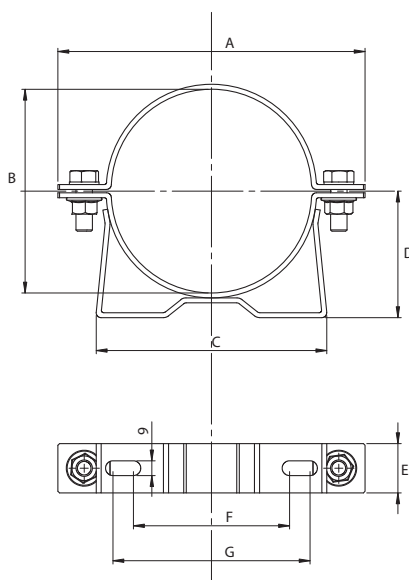

Codice OMT Group OMT Group code	Descrizione Description	A	B	C	D	E	F	G
COLLARE-C-114	COLLARE CS DIAM.114	187	112/124	140	77	30	95	120
COLLARE-C-169	COLLARE CS DIAM.169	240	160/180	182	90	40	-	140
COLLARE-C-219	COLLARE CS DIAM.219	300	200/225	270	120	40	202	222

**PER ACCUMULATORI A MEMBRANA
FOR DIAPHRAGM ACCUMULATORS**

Acciaio zincato / Guarnizione NBR
Galvanized Steel / NBR seal

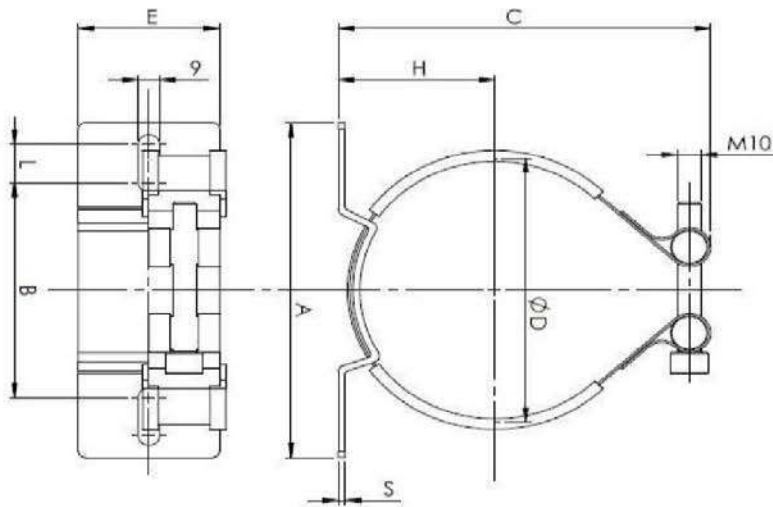

Codice OMT Group OMT Group code	Descrizione Description	A	B	C	D from-to	H from-to	E	L	S
COLLARE-C-62/65	Collare CS Ø 62/65 con staffa	120	85	85	62-65	38-39,5	40	8	3
COLLARE-C-73/77	Collare CS Ø 73/77 con staffa	120	85	96	73-77	43,5-45	40	8	3
COLLARE-C-89/92	Collare CS Ø 89/92 con staffa	120	85	112	89-92	51-52,5	40	8	3
COLLARE-C-100/106	Collare CS Ø 100/106 con staffa	156	100	135	100-105	59-62	60	18	3
COLLARE-C-106/114	Collare CS Ø 106/114 con staffa	156	100	143	106-114	62,5-66	60	18	3
COLLARE-C-121/129	Collare CS Ø 121/129 con staffa	156	100	165	121-129	75,5-80	60	18	3
COLLARE-C-133/142	Collare CS Ø 133/142 con staffa	156	100	174	133-142	76,5-82,5	60	18	3
COLLARE-C-143/151	Collare CS Ø 143/151 con staffa	156	100	182	143-151	83-86,5	60	18	3
COLLARE-C-152/159	Collare CS Ø 152/159 con staffa	156	100	191	152-159	87-91	60	18	3
COLLARE-C-167/175	Collare CS Ø 167/175 con staffa	236	152	207	167-175	92,5-96,5	60	32	4
COLLARE-C-176/185	Collare CS Ø 176/185 con staffa	236	152	241	176-185	97-102,5	60	32	4
COLLARE-C-202/210	Collare CS Ø 202/210 con staffa	236	152	245	202-210	116-120	60	32	4
COLLARE-C-209/217	Collare CS Ø 209/217 con staffa	236	152	255	209-217	122,5-126,5	60	32	4
COLLARE-C-216/224	Collare CS Ø 216/224 con staffa	236	152	256	216-224	120-124	60	32	4
COLLARE-C-223/230	Collare CS Ø 223/230 con staffa	236	152	259	223-230	120,5-123,5	60	32	4
COLLARE-C-225/234	Collare CS Ø 225/234 con staffa	236	152	265	225-234	123-127,5	60	32	4

Minimex in acciaio zincato
 Minimex in galvanized steel

Valvola di precarica dell'azoto 5/8" 18UNF in AISI 304/L
 OMT Group nitrogen precharge valve 5/8" 18UNF in AISI 304/L

Vedere pag. 28 - Valvola azoto
 See page 28 - Nitrogen valve

BLOC-SS-14-O

Blocco per accumulatori a sacca in acciaio inox
 Stainless steel bladder accumulator block

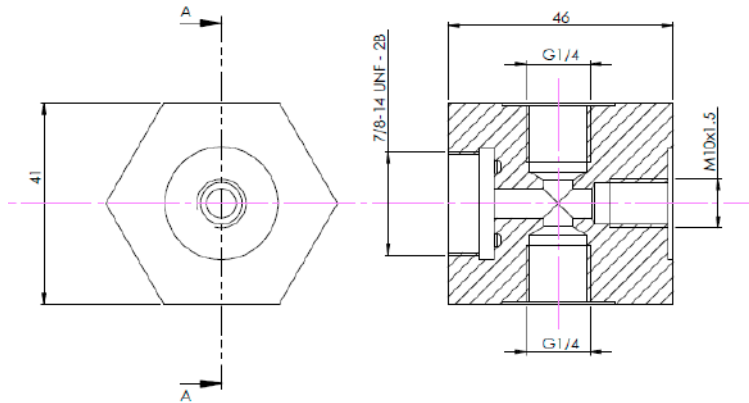

Min-14-Capmet
 Minimex



BLOC-CS-2-O

Blocco per accumulatori a sacca in acciaio al carbonio
 Carbon steel bladder accumulator block

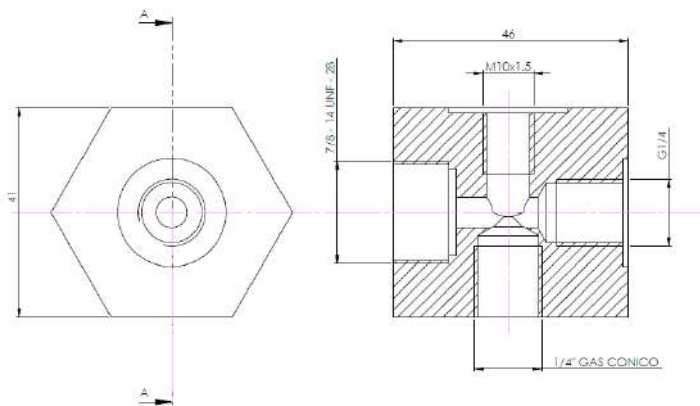

FT290-14
 Esclusore manometro
 Gauge isolator



BLOC-SS-20-O

Blocco per accumulatori a membrana in acciaio Inox
 Stainless steel diaphragm accumulator block

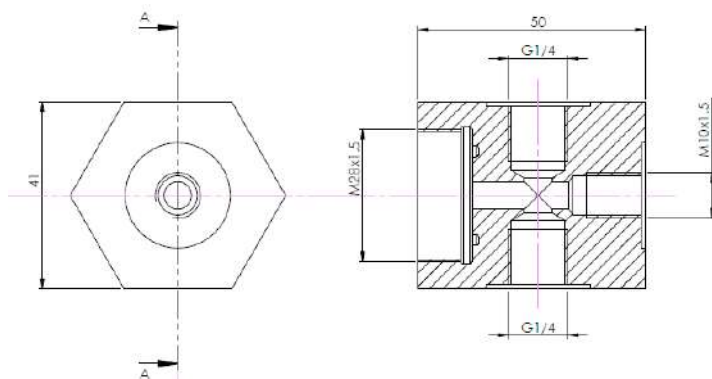

Fornibili su richiesta customizzati:

- esclusore manometro
- manometro
- disco di rottura certificato
- minimex
- valvola azoto OMT Group

Available customized version on request:

- gauge isolator
- gauge
- certified burst disc
- minimex
- OMT Group nitrogen valve

KIT DI RICARICA AZOTO UNIVERSALE UNIVERSAL NITROGEN CHARGING KIT

Il VGUPKIT, tester universale e pressurizzatore, è uno strumento indispensabile per la verifica, la pressurizzazione e lo spurgo di azoto della maggior parte degli accumulatori idraulici disponibili sul mercato.

Per utilizzarla questa unità è avvitata sulla valvola di gonfiaggio dell'accumulatore e collega un tubo flessibile ad alta pressione alla bombola di azoto.

Applicazioni:

- Gonfiaggio degli accumulatori
- Gonfiaggio degli accumulatori dopo la sostituzione della vescica
- Controllo periodico di precarica degli accumulatori
- Controllo di precarica degli accumulatori durante la fase di installazione
- Variazione di precarica degli accumulatori

The VGUPKIT, universal tester and pressurizer is an indispensable instrument for the verification, pressurization and nitrogen bleeding of most of the hydraulic accumulator available on the market.

To use this unit, it's screwed on the inflation valve of the accumulator and connect a high pressure hose to nitrogen bottle.

Applications:

- Accumulators tool inflation
- Accumulators inflation after the replacement of the bladder
- Accumulators pre-charge periodic check
- Accumulators pre-charge check during the installation phase
- Accumulators pre-charge variation

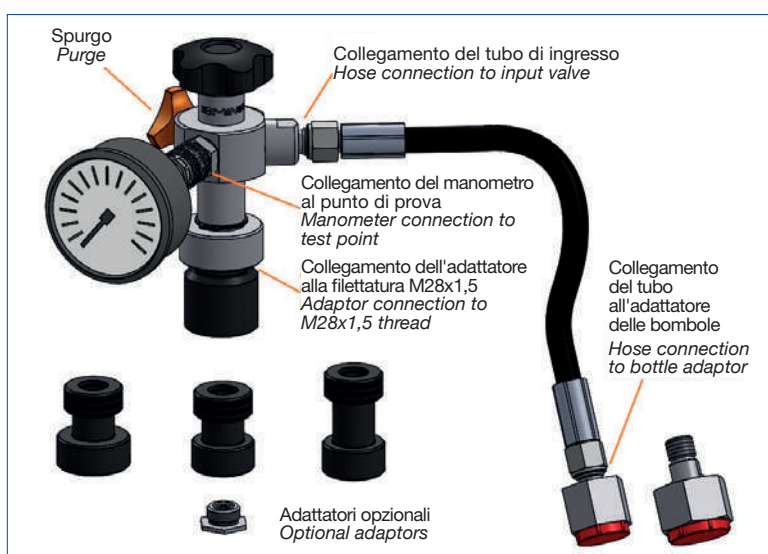

Codice OMT Group OMT Group Code	Note Note	Adattatore per le bombole di azoto Nitrogen bottle adaptor Senza/Without
VGUPKIT-25-250	General market	W21,8x1,814
VGUPKIT-ITA-25-250	Italian market	W21,7x1,814
VGUPKIT-FR-25-250	France market	W24,32x1,814
VGUPKIT-DE-25-250	Germany market	

STANDARD KIT COMPONENTS: WEIGHT 3,9 KG

Plastic box - Plastic box		
Strumento di ricarica Charging tool shell	Pmax 400bar	M28 x 1,5
Tubo flessibile Flexi tube about	2m - Pmax 400bar	¼ - ¼
Adattatore per bombola (vedere tab. codice OMT Group) Bottles adaptor (please see table OMT Group code)		D63mm (0-25)Bar – minimex connection
manometro a bagno di glicerina Pressure gauge with glycerin		D63mm (0-250)Bar – minimex connection
Set di guarnizione Gasket set	VGUPKIT	
Adattatore per accumulatore di azoto Nitrogen accumulator valve adaptor		M28x1,5 - 5/8" 18 UNG 5/8" 18UNF - 5/16 (8V1) Schreuder valve M28x1,5 - M16x2 M28x1,5 - 7/8" 14UNF M28x1,5 - ¾"
Vite a cava esagonale Hexagon sock screw		Key 6mm

MODELLO - MODEL : VGUPKIT-25-250

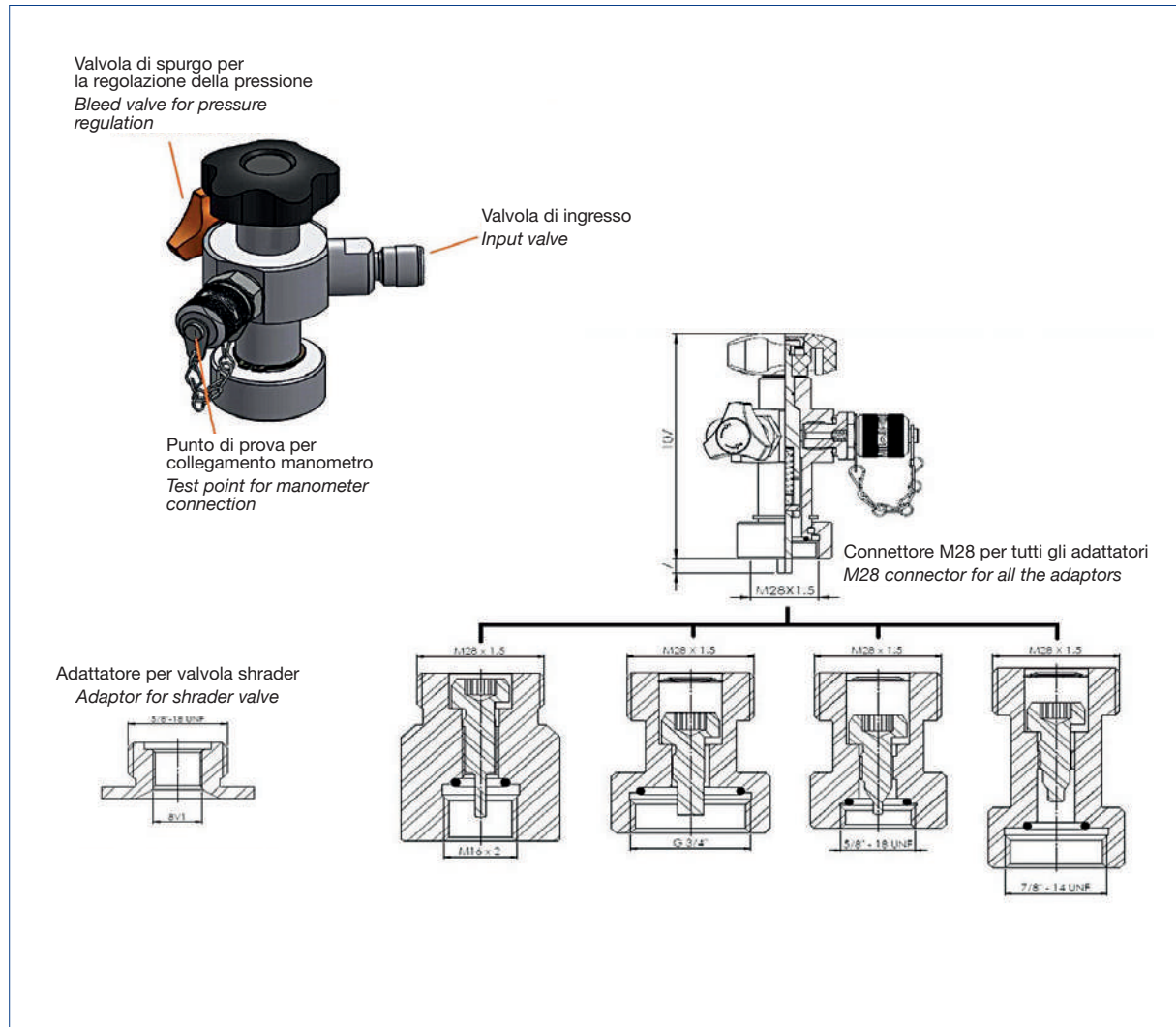

ADATTATORI PER ATTACCO BOMBOLE
ADAPTORS FOR BOTTLE CONNECTION

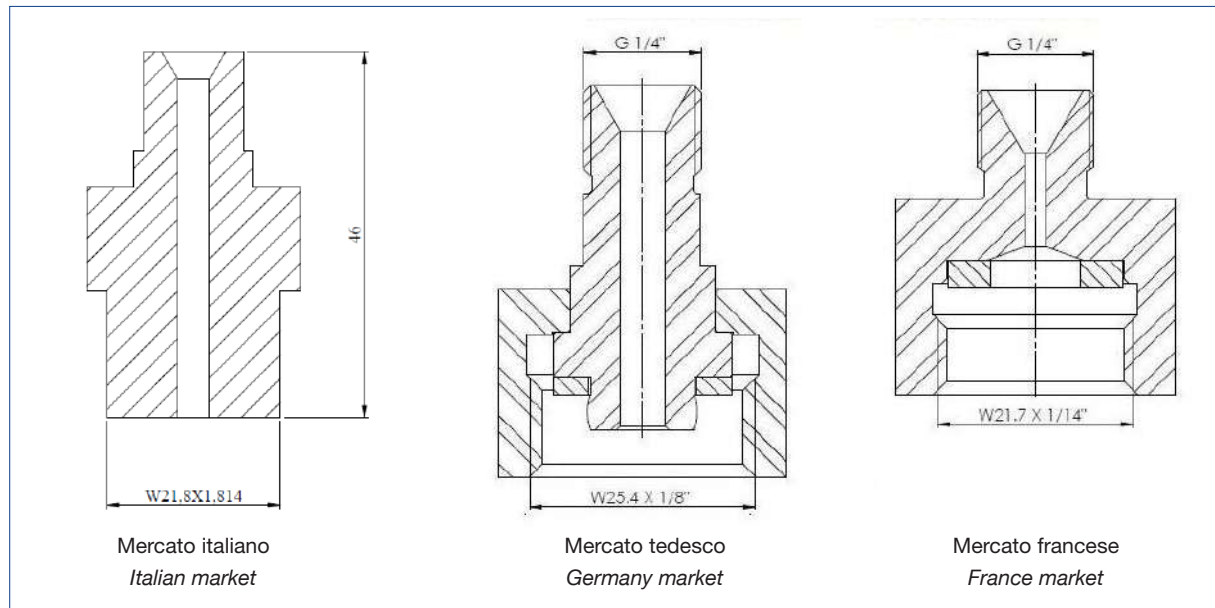

BLOCCO DI SICUREZZA ACCUMULATORI
SAFETY BLOCK ACCUMULATORS

- Acciaio al carbonio C40 / AISI420 rubinetto a sfera / guarnizione NBR
- Predisposizione per valvola solenoide CETOP 3

- Carbon Steel C40 / AISI420 ball / NBR seal
- Predisposal for solenoid valve CETOP 3



GRANDEZZA
SIZE
16

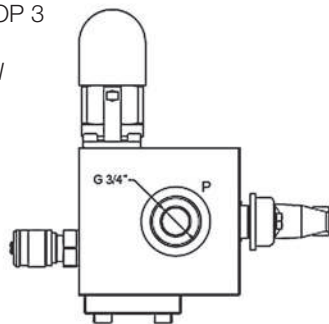

Versione SB16 ME-200-N

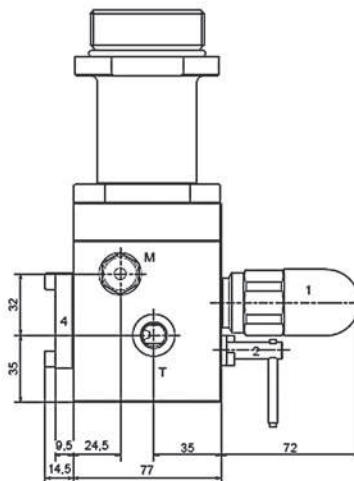
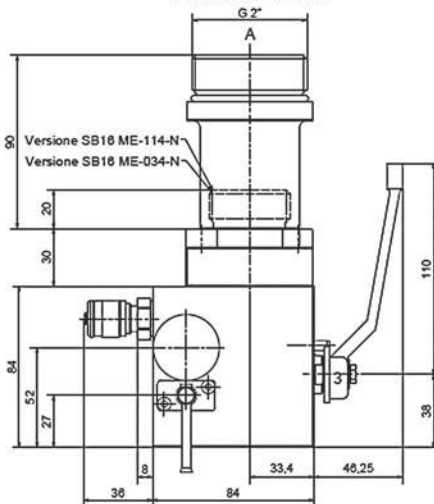
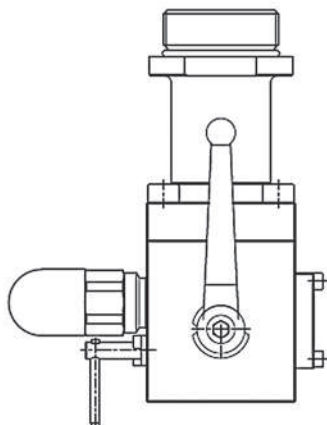
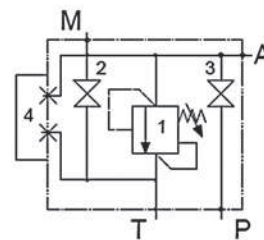

Codice Code	Descrizione Description	Grandezza Size	Attacco olio ? Oil Port	Tipo di accumulatore Accumulator Type
SB16ME-200-N	Safety block 16ME 2" NBR	16	3/4" G	10/50L 2"
SB16ME-114-N	Safety block 16ME 1"1/4 NBR	16	3/4" G	<10L 1"1/4
SB16ME-034-N	Safety block 16ME 3/4" NBR	16	3/4" G	<10L 3/4"



GRANDEZZA
SIZE
24

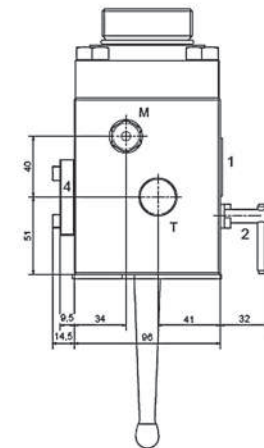
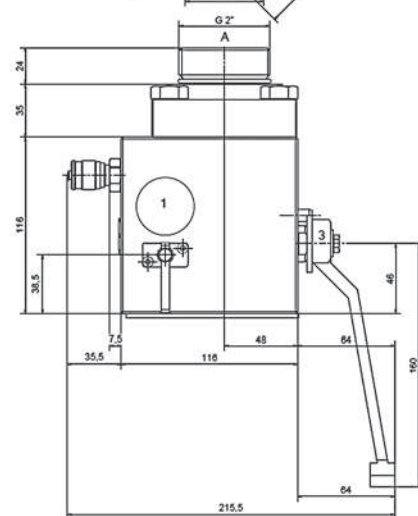
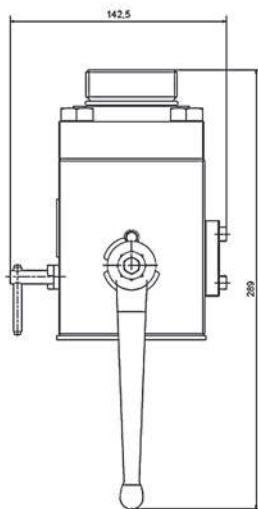
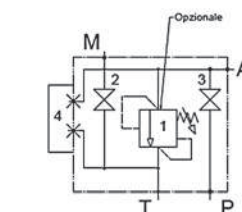
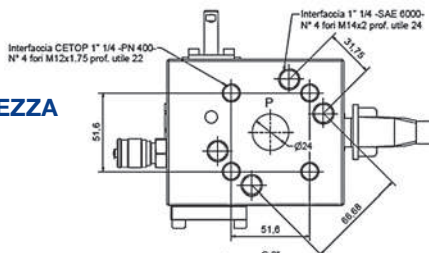

Codice Code	Descrizione Description	Grandezza Size	Attacco olio ? Oil Port	Tipo di accumulatore Accumulator Type
SB24ME-200-N	Safety block 24ME 2" NBR	24	1"1/4 SAE + CETOP	10/50L 2"
SB24ME-200-NP	Safety block 24ME 2" NBR	24	1"1/4 SAE + CETOP	Piston serie

- Acciaio al carbonio CE PED
- Carbon Steel CE PED

GRANDEZZA - SIZE 6 - 10

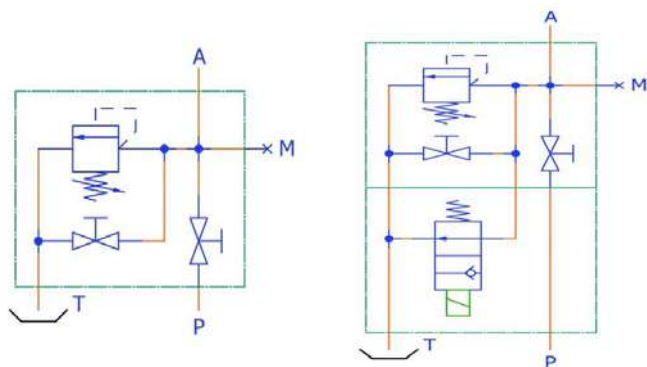

Codice set standard Code standard set	Descrizione Description	Grandezza Size	Approvazione Approval	Installato su Installed on
8207-82071720-210	Safety valve DBD-S-10K13-210-CE	10	CE	SB24
8207-82071740-250	Safety valve DBD-S-10K13-250-CE	10	CE	SB24
8207-82071850-330	Safety valve DBD-S-10K13-330-CE	10	CE	SB24
8206-82061230-210	Safety valve DBD-S-6K13-210-CE	6	CE	SB16
8206-82061320-250	Safety valve DBD-S-6K13-250-CE	6	CE	SB16
8206-82061450-330	Safety valve DBD-S-6K13-330-CE	6	CE	SB16

OMT.007.236.000

Versione con accumulatori
Version with accumulators

OMT.007.236.N00

Versione senza accumulatori
Version without accumulators

Attacchi
Connections

(GA e DA - 1/2" GAS) - (B P G D - 3/8" GAS) - (M MD MG - 1/4" GAS)

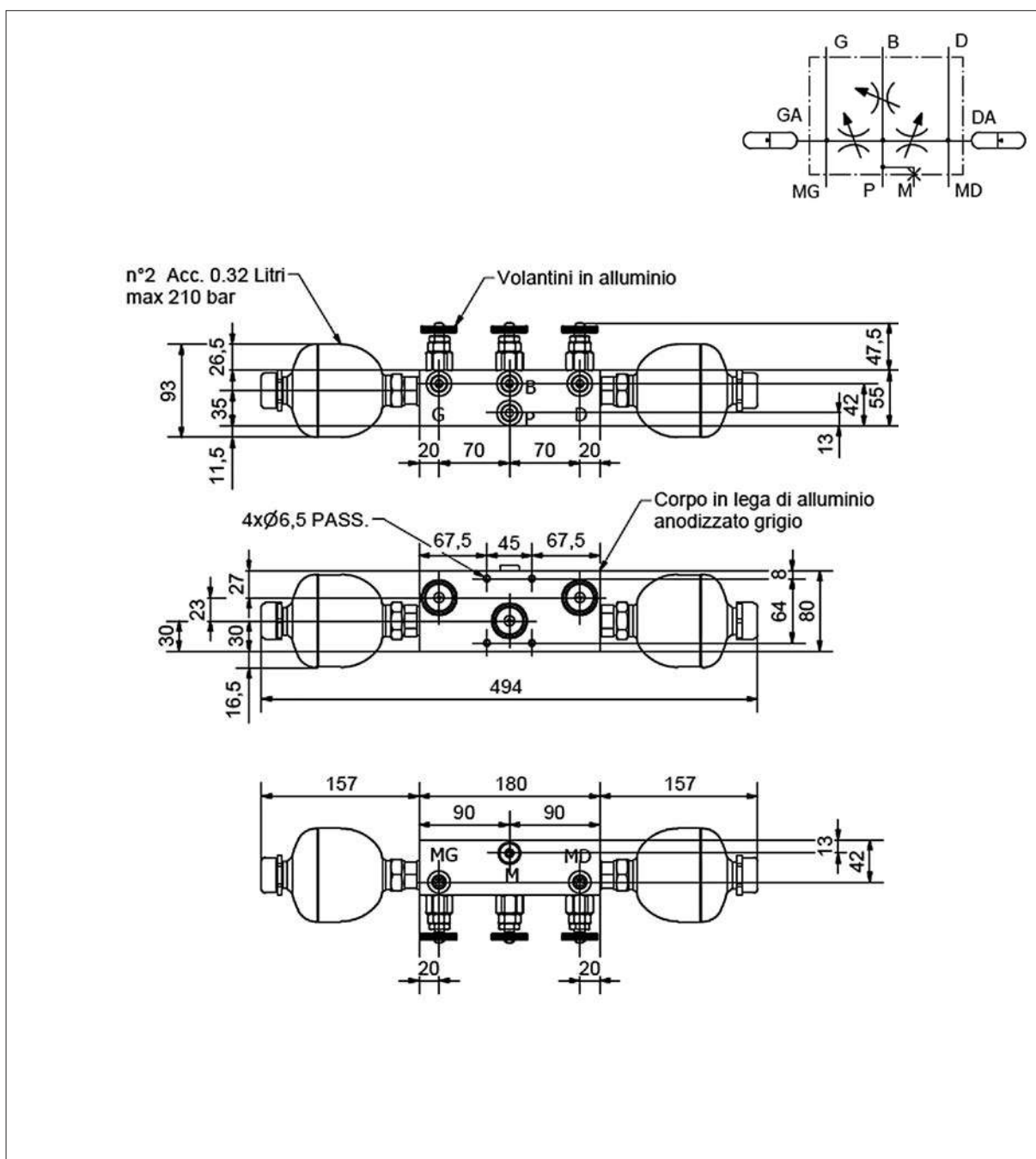

OMT.007.243.000

Attacchi
 Connections

(Porte accumulatore/Accumulator ports - 1/2" GAS)
(A B - 3/8" GAS) - (P1 P2 M1 M2 - 1/4" GAS)

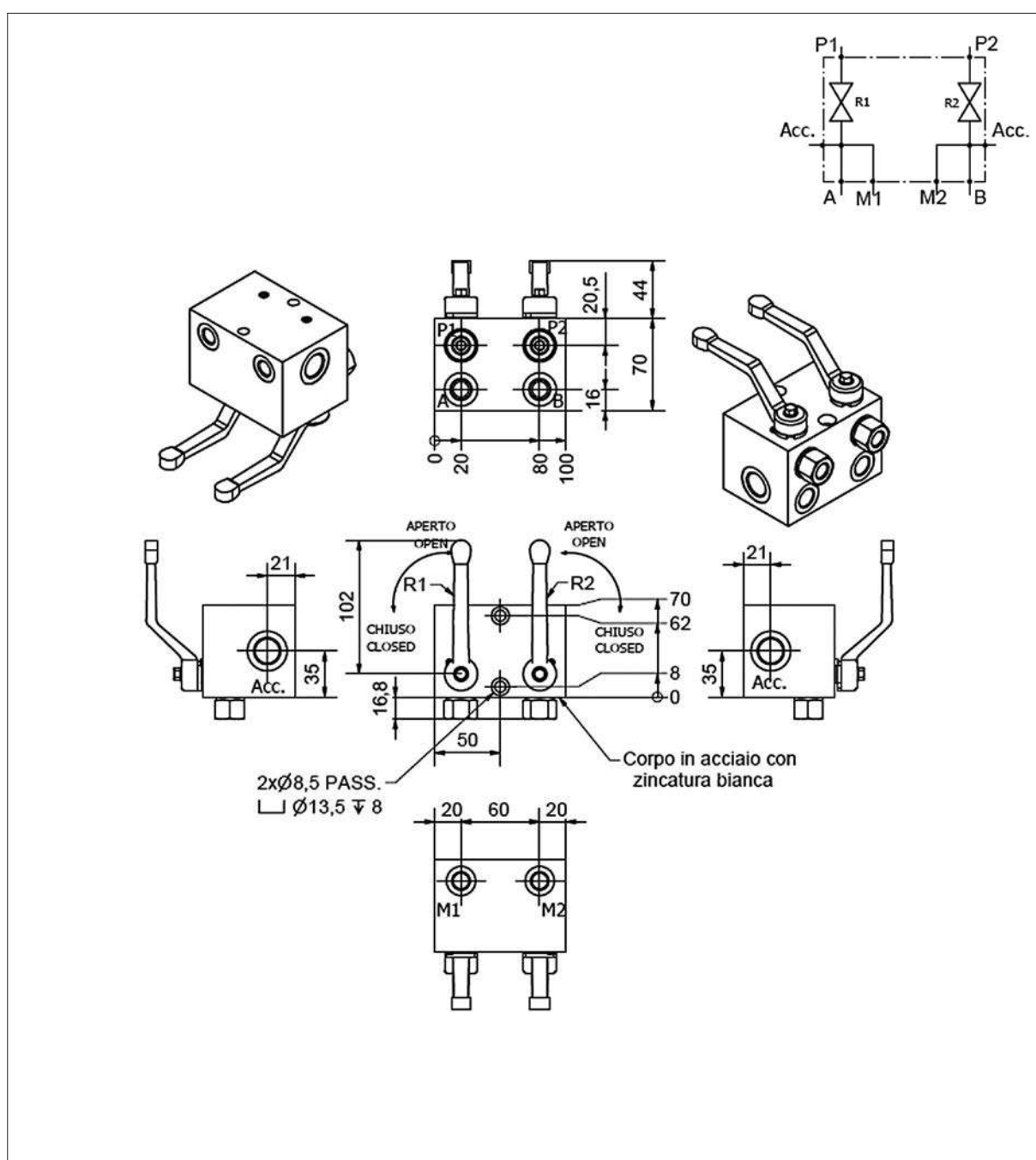

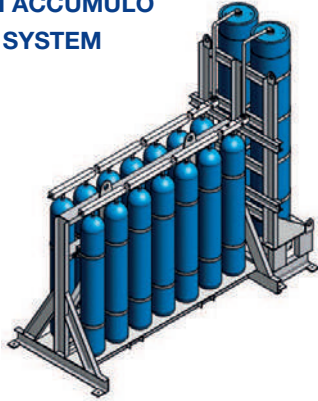
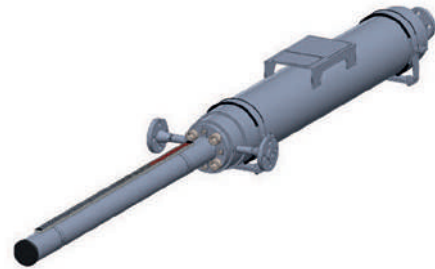
**SISTEMA DI ACCUMULO
TRANSFER SYSTEM****APPLICAZIONI OIL&GAS
INTENSIFICATORE DI PRESSIONE OLIO/OLIO****OIL&GAS APPLICATION
OIL OIL PISTON INTENSIFIER****BALLUFF****SENSORI DI POSIZIONAMENTO
LINEARE MAGNETOSTRITTIVI
IN CUSTODIA
A PROFILO**

I sensori di posizionamento lineare magnetostrittivi a profilo sono sistemi a misurazione contactless e assoluta per il rilevamento preciso di una o più posizioni. Convincono negli ambienti gravosi, ad esempio in presse, macchine per stampaggio a iniezione o robot a portale, poiché dispongono di una custodia in alluminio IP67 a tenuta ermetica. I magneti del sensore di posizione agiscono attraverso la parete del profilo sull'elemento di misurazione.

**MAGNETOSTRICTIVE LINEAR POSITION
SENSORS IN PROFILE HOUSING**

Linear position sensors with a profile design are contact-free and absolute measurement systems for the precise detection of one or more positions. They deliver convincing performance in harsh environments, for example in presses, injection molding machines or gantry robots, because they are made of a hermetically sealed IP67 aluminum housing. The magnets of the position encoder act on the measurement element through the wall of the profile.





MANAGEMENT SYSTEM CERTIFICATE

Certificate no.:
68359-2009-AQ-ITA-SINCERT

Initial certification date:
30 October 2009

Valid:
31 October 2021 – 30 October 2024

This is to certify that the management system of
OMT Group S.p.A. - Sede Legale e Operativa
Via Lombardia, 14 - 24040 Calvenzano (BG) - Italy

has been found to conform to the Quality Management System standard:
ISO 9001:2015

This certificate is valid for the following scope:
Design and manufacture of Heat Exchangers, components for hydraulic applications, pressure bladder and piston accumulators and industrial systems for large volume accumulators. Design, manufacture and marketing of hydraulic valves and related integrated groups.
(IAF: 18, 17)

Place and date:
Vimercate (MB), 14 February 2022



SCD N° 001 A
SCA N° 001 D
SCS N° 001 F
SCS N° 004 F

EN45 006 #
PRD N° 033 F
PRD N° 036 C
SCS N° 002 G

Per informazioni sulla PA, per gli adempimenti di certificazione:
ACCREDITED UNIT: DNV Business Assurance Italy S.r.l., Via Energy Park, 14 - 20871 Vimercate (MB) - Italy - TEL: +39 69 99 905 - www.dnv.it

For the issuing office:
DNV - Business Assurance
Via Energy Park, 14 - 20871 Vimercate (MB) - Italy

Claudia Baroncini

Claudia Baroncini
Management Representative

Lack of fulfillment of conditions as set out in the Certification Agreement may render this Certificate invalid.
ACCREDITED UNIT: DNV Business Assurance Italy S.r.l., Via Energy Park, 14 - 20871 Vimercate (MB) - Italy - TEL: +39 69 99 905 - www.dnv.it

SISTEMA DI GESTIONE QUALITÀ QUALITY MANAGEMENT SYSTEM

Stante il continuo miglioramento dei nostri prodotti, è possibile che il catalogo subisca delle modifiche anche senza il preavviso delle stesse. Si suggerisce vivamente di verificare il contenuto dei cataloghi. Per avere la certezza di essere in possesso dell'ultima versione visita il sito: www.omtgroup.it/cataloghi
Questa versione annulla e sostituisce le precedenti.

Given the continuous improvement of our products, it is possible that the catalog undergoes changes even without prior notice.
It is strongly recommended that you check the contents of the catalogs. To be sure of being in possession of the latest version, visit the website: www.omtgroup.it/en/catalogs
This version cancels and replaces the previous ones.





OMT Group S.p.A.
Via Lombardia, 14
24040 Calvenzano (BG) - Italy
Tel.: +39 0363 86.03.11
Fax: +39 0363 33.56.20

 www.omtgroup.it

 omtgroup@omtgroup.it

    OMT Group

